



A review of impacts of marine dredging activities on marine mammals

Victoria L. G. Todd^{1,2*}, Ian B. Todd^{1,2}, Jane C. Gardiner¹, Erica C. N. Morrin¹, Nicola A. MacPherson¹, Nancy A. DiMarzio¹, and Frank Thomsen³

¹Ocean Science Consulting Ltd (OSC), Ocean House, 4 Brewery Lane, Belhaven, Dunbar, East Lothian EH42 1PD, UK

²Institute of Sound and Vibration Research, University of Southampton, Southampton, Highfield, Hampshire SO17 1BJ, UK

³DHI, Agern Allé 5, DK-2970 Hørsholm, Denmark

*Corresponding author: tel: +44 1368 865 722; fax: +44 1368 865 729; e-mail: vt@osc.co.uk

Todd, V. L. G., Todd, I. B., Gardiner, J. C., Morrin, E. C. N., MacPherson, N. A., DiMarzio, N. A., and Thomsen, F. A review of impacts of marine dredging activities on marine mammals. – ICES Journal of Marine Science, doi: 10.1093/icesjms/fsu187.

Received 1 May 2014; revised 19 September 2014; accepted 7 October 2014.

Marine dredging is an excavation activity carried out worldwide by many industries. Concern about the impact dredging has on marine life, including marine mammals (cetaceans, pinnipeds, and sirenians) exists, but effects are largely unknown. Through consulting available literature, this review aims to expand on existing knowledge of the direct and indirect, negative and positive impacts on marine mammals. In terms of direct effects, collisions are possible, but unlikely, given the slow speed of dredgers. Noise emitted is broadband, with most energy below 1 kHz and unlikely to cause damage to marine mammal auditory systems, but masking and behavioural changes are possible. Sediment plumes are generally localized, and marine mammals reside often in turbid waters, so significant impacts from turbidity are improbable. Entrainment, habitat degradation, noise, contaminant remobilization, suspended sediments, and sedimentation can affect benthic, epibenthic, and infaunal communities, which may impact marine mammals indirectly through changes to prey. Eggs and larvae are at highest risk from entrainment, so dredging in spawning areas can be detrimental, but effects are minimized through the use of environmental windows. Sensitive environments such as seagrass beds are at risk from smothering, removal, or damage, but careful planning can reduce degradation. Assessing impacts of contaminant remobilization is difficult, but as long as contaminated sediments are disposed of correctly, remobilization is limited in space and time. Effects of suspended sediments and sedimentation are species-specific, but invertebrates, eggs, and larvae are most vulnerable. Positive effects, including an increase in food, result from greater nutrient loads, but are often short term. Dredging has the potential to impact marine mammals, but effects are species and location-specific, varying also with dredging equipment type. In general, evidence suggests that if management procedures are implemented, effects are most likely to be masking and short-term behavioural alterations and changes to prey availability.

Keywords: aggregate dredging, anthropogenic noise, behavioural response, marine mammals, sedimentation, turbidity.

Introduction

Dredging is a worldwide excavation activity that involves removing sediment from a sea, river, or lakebed and depositing it at a new location. Uses are vast and include construction of ports, waterways, dykes, and other marine infrastructure, land reclamation, flood and storm protection, extraction of mineral resources to provide material for the construction industry (e.g. for road construction), and in environmental remediation of contaminated sediments (see reviews by Brunn *et al.*, 2005; Thomsen *et al.*, 2009; CEDA, 2011; Tillin *et al.*, 2011; WODA, 2013). Here, we focus on dredging in the marine environment, except fisheries.

Four main types of dredger, cutter suction dredgers (CSDs), trailing suction hopper dredgers (TSHDs), grab dredgers, and backhoe dredgers, are used commonly for dredging operations (Figure 1).

Regulations, project requirements, and nature of the seabed determine which dredger is used; processes vary substantially between types. Hydraulic dredgers, such as CSDs and TSHDs, use suction to move material from the seabed to a barge, hopper, or pipeline. CSDs are best suited to removing hard substrates, as a rotating cutter head breaks up material on the seabed before its removal by suction pipe. TSHDs, on the other hand, are ideal for removing loose sediments,

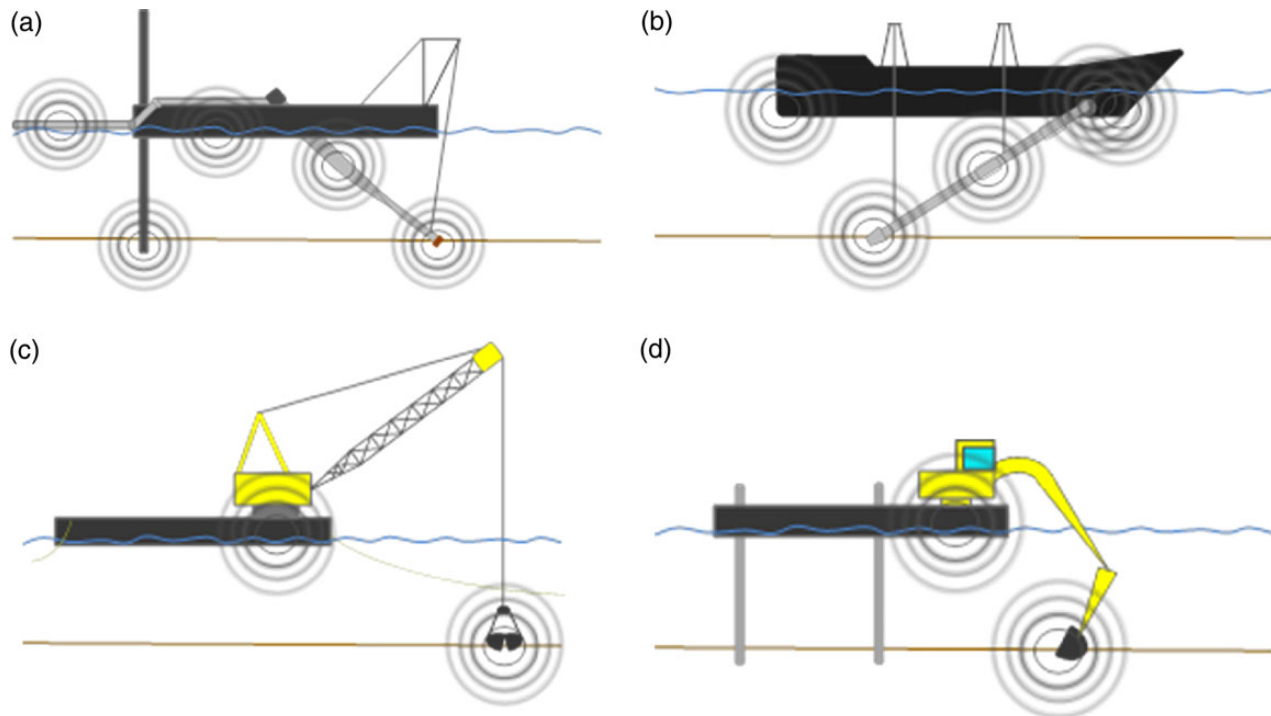

Figure 1. Common examples of dredgers and possible sound sources (a) CSD, (b) TSHD, (c) grab, and (d) backhoe (adapted from CEDA, 2011; WODA, 2013).

as the suction pipe or drag head is dragged behind the vessel and removes material while in transit. Grab and backhoe dredgers are mechanical and moored on site. Rather than using suction, grab dredgers use a crane-operated clamshell bucket to scrape material off the seabed. Once closed, the bucket is brought to the surface, and sediment deposited onto a separate barge. Backhoe dredgers are similar, but a hydraulic arm operates a bucket from the rear of the vessel (EUDA, 2014).

Marine aggregates are an essential resource. In waters around England and Wales alone, 20 million t of marine sand and gravel are dredged annually (Tillin *et al.*, 2011). Activity is not spaced uniformly, but instead confined to certain areas, or hotspots; in the UK, most dredging occurs around the Southeast coast (Tillin *et al.*, 2011). Expanding to continental Europe, most dredging is carried out in coastal areas of Netherlands and Denmark (Velegrakis *et al.*, 2010). In 2012, total turnover for dredging contractors worldwide was estimated to be €11 370 million, which is more than double the turnover in 2000 (IADC, 2012). Population growth and increasing number and size of infrastructure projects mean demand is growing continually worldwide, so amount of dredging, volume of aggregates, and turnover will most likely increase.

Since dredging impacts the marine environment, sustainable management of the activity is required, based on an in-depth understanding of how dredging affects marine habitats and associated fauna and flora. To date, the positive and negative effects of dredging on marine flora, benthic infauna, and the seabed are relatively well documented (see reviews by Newell *et al.*, 1998; Thrush and Dayton, 2002; Hitchcock and Bell, 2004; Erfteimeijer and Lewis, 2006; Tillin *et al.*, 2011; Erfteimeijer *et al.*, 2012). Conversely, although many marine mammal species inhabit coastal regions, where intensive construction activities (including dredging) occur

(see, for example, Chilvers *et al.*, 2005; Coll *et al.*, 2012; Anderwald *et al.*, 2013; Pirootta *et al.*, 2013), the direct and indirect impacts on marine mammals are less well understood.

As a whole, marine mammals are dispersed widely, but distribution of individual species and populations is patchy, with certain areas comprising higher animal densities than others. Critical areas that provide ideal conditions for essential activities such as breeding, nursing, or feeding can be vital to a populations' ability to survive and grow. Interference with these habitats, which could be caused by dredging, may impact upon local distribution and abundance.

This paper aims to synthesize existing knowledge on the impacts of dredging on marine mammals, in the hope that environmental management of dredging activities will improve. Peer-reviewed scientific publications, books, and non-peer-reviewed consultancy and technical reports have been reviewed and discussed in relation to marine mammals, focusing on cetaceans (whales, dolphins, and porpoises), pinnipeds (eared seals, earless seals, and walrus), and sirenians (dugongs and manatees). For brevity, otters, polar bears, and freshwater cetaceans have not been discussed. For the guidance of impact assessments, a comprehensive reference table detailing hearing ranges, habitat, regional distribution, and diet preferences of all marine mammals, along with documented and predicted effects of dredging, has been provided in the Supplementary material.

Direct impacts

Physical injury or mortality from collisions, noise production, and increased turbidity are the main ways dredging can affect marine mammals directly.

Collisions

Collision with vessels is a known cause of injury and mortality in marine mammals (see reviews by Laist *et al.*, 2001; Jensen and Silber, 2003; Van Waerebeek *et al.*, 2007; Neilson *et al.*, 2012). Vessel movement is associated with all stages of dredging, from transit from the extraction site and dumping grounds to operation of the dredger itself. Thus, collision with dredgers is possible, but only one incident is evident in the literature; it resulted in the death of a southern right whale (*Eubalaena australis*) calf (Best *et al.*, 2001).

Research into marine mammals and vessel collisions in general has demonstrated that the likelihood of collision varies, depending on a number of factors, including vessel type, speed, location, species, and behaviour (Laist *et al.*, 2001; Van Waerebeek *et al.*, 2007).

Although vessel strikes are reported for all marine mammals, most research has focused on mysticetes. Studies have shown that the risk of a collision occurring and the likelihood that it will result in severe or lethal injury increases when vessels exceed 10–14 kn (Laist *et al.*, 2001; Vanderlaan and Taggart, 2007; Gende *et al.*, 2011; Neilson *et al.*, 2012; Lammers *et al.*, 2013). The influence of vessel size or type appears less significant. Right whales (*Eubalaena* spp.), humpback whales (*Megaptera novaeangliae*), and fin whales (*Balaenoptera physalus*) are considered some of the most prone to collisions (Laist *et al.*, 2001; Van Waerebeek *et al.*, 2007), and calves and juveniles are struck most commonly (Laist *et al.*, 2001; Neilson *et al.*, 2012; Lammers *et al.*, 2013). Resting or feeding whales were deemed more at risk by Laist *et al.* (2001), and Panigada *et al.* (2006) reported seasonal changes in collision rate of fin whales, with rates increasing during months when intensive feeding occurs. This is due possibly to the fact that feeding animals are distracted, and less focused on vessel movements (Laist *et al.*, 2001).

Data on vessel collisions need to be assessed with caution, as much of what we know is obtained from historical or anecdotal records that are difficult to verify. Data from strandings are useful, but identifying the cause is often based on speculation from injuries, which may not be obvious or could be attributed to a number of sources. Nevertheless, based on evidence presented, and given that active dredgers are stationary, or move at slow speeds of 1–3 kn (Reilly, 1950), if dredging is well managed, avoids critical habitats, times when animals may be distracted, or areas where calves are abundant, risk of collision between marine mammals and active dredgers is minimal. Collision risk is perhaps greater when dredgers are in transit, as speeds can reach ca. 12–16 kn (Brunn *et al.*, 2005), but in areas already characterized by heavy shipping traffic, the addition of dredging vessels is unlikely to increase the collision risk substantially (Tillin *et al.*, 2011).

Noise levels

Marine mammals, particularly cetaceans, are acoustically reliant animals that utilize sound for detecting prey, navigating, and communicating. Knowledge on the effects of anthropogenic noise on marine mammals has improved due to extensive research over the past two decades, although many information gaps still exist (see, for example, Croll *et al.*, 2001; Gerstein *et al.*, 2006; Southall *et al.*, 2007; Weilgart, 2007; Wright *et al.*, 2007; OSPAR, 2009; Popov *et al.*, 2011; Thomsen *et al.*, 2011; Di Iorio and Clark, 2012). Reported effects include temporary threshold shift (TTS) or permanent threshold shift (PTS), the latter being considered as

auditory injury (Nachtigall *et al.*, 2003; Kastak *et al.*, 2005; Lucke *et al.*, 2009; Mooney *et al.*, 2009). Other effects include acoustic masking, which could cause animals to alter the duration, frequency, or sound level of acoustic signals. Masking of important sounds can theoretically impact reproductive success of individual whales, and in turn affect populations (Croll *et al.*, 2001; Clark *et al.*, 2009). Behavioural changes due to noise exposure can happen at large distances from the source, and may be costly biologically, as they could affect energy expenditure, or limit the amount of time spent feeding or resting (see NRC, 2005). It has been hypothesized that noise impacts have the potential to induce stress (Wright *et al.*, 2007; see also Rolland *et al.*, 2012). Stress could reduce the foraging efficiency of marine mammals or increase their susceptibility to disease and the effects of toxins (Geraci and Lounsbury, 2001; Reynolds *et al.*, 2005; Perrin *et al.*, 2009).

Published results of noise for dredgers used most commonly are highlighted in recent reviews such as Thomsen *et al.* (2009), CEDA (2011), and WODA (2013). In general, dredging produces continuous, broadband sound with main energy below 1 kHz. Sound pressure levels (SPLs) can vary widely, for example, with dredger type, operational stage, or environmental conditions.

Greene (1987) undertook noise measurements of two CSDs; received SPLs were 133 dB re 1 μ Pa and 140 dB re 1 μ Pa at distances of 0.19 and 0.2 km from the dredgers respectively (bandwidth = 20 Hz–1 kHz). Noise levels of a CSD used in New York and New Jersey harbour were recorded during rock fracturing; the maximum received SPL of 149.3 dB re 1 μ Pa rms was recorded at a distance of 89 m from the dredger. Based on a 15 log ($R/1$ m) scaling, the calculated source levels reached 175 dB re 1 μ Pa at 1 metre (bandwidth = 3 Hz–20 kHz; Reine *et al.*, 2012b).

Noise produced by TSHDs has been measured on a number of occasions, and in general reported sound levels appear higher than ones documented for CSDs. Robinson *et al.* (2011) measured six TSHDs, stating that sound levels below 500 Hz were in line with those expected for a cargo ship travelling at modest speeds (8–16 kn). The maximum broadband source SPL was 189.9 dB re 1 μ Pa at 1 metre (calculated based on 1/3 octave band levels from 31.6 Hz to 39.8 kHz, as reported by Robinson *et al.*, 2011). Estimated 1/3 octave band source levels above 1 kHz were relatively high, which was probably a result of the coarse aggregate pumped through the dredge pipe. Using an identical approach, de Jong *et al.* (2012) found very similar results to Robinson *et al.* (2011), but 1/3 octave band source levels clearly showed a steady decline beyond 1 kHz. This was due to the material dredged (sand as opposed to gravel).

Noise produced by grab dredgers varies substantially with operational stage. Dickerson *et al.* (2001) measured SPLs at 0.15 km from a grab dredger throughout the entire process. The loudest SPLs of 124 dB re 1 μ Pa were recorded at peak frequencies of 0.16 kHz, when the bucket made impact with the seabed.

Noise levels emanating from a backhoe dredger operating around the Shetland Islands, UK, were recorded by Nedwell *et al.* (2008). Using a scaling of 10 log ($R/1$ m), the back-calculated source level was 163 dB re 1 μ Pa at 1 metre (bandwidth = 20 Hz–100 kHz). In contrast, Reine *et al.* (2012a) calculated source levels of 179 dB re 1 μ Pa at 1 metre (bandwidth = 3 Hz–20 kHz), but the used scaling was different [15 log ($R/1$ m)], so results are difficult to compare.

Knowledge about the hearing range of cetacean species is only available partly, but it is assumed generally, that whales and dolphins hear over similar frequency ranges to the sounds they produce,

although hearing ranges can extend beyond that of frequencies used for vocalizations (review by Southall *et al.*, 2007). If anthropogenic noise, such as that produced during dredging operations, coincides with species' hearing ranges, it has the potential to affect individuals and populations of marine mammals present within the area at the time. Looking at the overlap between dredging noises on the one hand, and suspected hearing sensitivity of marine mammals on the other, it can be assumed that all marine mammals are prone to noise impacts from dredging, although the issue might be more acute for baleen whales which communicate at very low frequencies (see Thompson *et al.*, 1979; Au *et al.*, 2000; Tervo *et al.*, 2012). Toothed whales (odontocetes; including larger toothed whales, dolphins, and porpoises) produce a variety of sounds for communication and echolocation, including narrowband, frequency-modulated (FM) continuous tonal sounds known as whistles (0.5–>80 kHz), and broadband sonar clicks (0.25–220 kHz) including burst pulse sounds (Au *et al.*, 2000; Gordon and Tyack, 2002). The range of best hearing in the species documented so far is shifted to frequencies well above 10 kHz with sensitivity below 1 kHz being relatively poor (see Southall *et al.*, 2007). Impacts of dredging noise are also a potential concern for pinnipeds, which utilize sound during social interactions and when locating mates (Schustermann *et al.*, 2001; Van Opzeeland *et al.*, 2010). If dredging activities were to occur in breeding areas, masking of biologically important noises could decrease the chances of reproduction in pinnipeds.

Based on the information provided above, reactions of marine mammals to dredging sound are expected to depend on types of dredger used and its state of operation, on the local sound propagation conditions, and the receiver characteristics with regard to the sensitivity and bandwidth of hearing. Given available information, sound levels that marine mammals are exposed to usually are below suspected injury thresholds or PTS (for exposure criteria, see Southall *et al.*, 2007); however, TTS cannot be ruled out if marine mammals are exposed to noise for prolonged periods [for a recent study on effects of long-term exposure in harbour porpoises (*Phocoena phocoena*), see Kastelein *et al.* (2012)]. In the literature, dedicated case studies on the effects of marine dredging activities on specific marine mammal species are rare, and isolating any reactions observed during dredging activities is difficult to achieve. It is thought that bowhead whales (*Balaena mysticetus*) are affected by industrial noise in general, but results from comprehensive studies on their reactions to drilling and dredging noise in the Canadian Beaufort Sea have been inconclusive with conflicting observations recorded. On a number of occasions in the early 1980's, bowhead whales were observed close to operating dredgers and drill ships (Richardson *et al.*, 1985, 1987, 1990). A longer-term comparison of data collected from the Canadian Beaufort Sea suggests that fewer animals were observed in total after 1980, when an increase in industrial activity, including dredging, occurred. It was hypothesized that, either cumulative effects of increased industrial activity led to habitat avoidance or alternatively, a change in prey distribution caused whales to occupy different areas (Richardson *et al.*, 1987).

While carrying out a study on grey whales (*Eschrichtius robustus*) in a lagoon in Baja California, Bryant *et al.* (1984) reported that industrial activities, including dredging, had led most likely to long-term changes in baleen whale distribution. The study reported that grey whales were almost absent completely from the lagoon during the many years of intense shipping and dredging activity, and returned only once shipping had ceased. Shipping itself is potentially a major

cause for disturbance in cetaceans (see Southall, 2005; OSPAR, 2009; and recent results in Rolland *et al.*, 2012), so the actual effect of dredging alone could not be determined.

More recently, Anderwald *et al.* (2013) stated that minke whales (*Balaenoptera acutorostrata*) off the coast of Ireland avoided areas of high construction vessel traffic (including dredgers) during installation of a gas pipeline. Data indicated that number of fishing boats was also correlated negatively with minke whale presence, which suggests avoidance was perhaps more related to vessel noise or presence in general, rather than of dredging or construction specifically.

Using passive acoustic monitoring techniques, Diederichs *et al.* (2010) found short-term avoidance in harbour porpoises at ranges of 600 m from a TSHD operating to the west of Sylt (Northern Germany). In the Port of Anchorage, near the head of Cook Inlet (south-central Alaska), declines in the beluga whale (*Delphinapterus leucas*) population have also been investigated in relation to dredging works. Results were inconclusive, with beluga whales often sighted in proximity to operating dredgers, but it was noted that they could have habituated over time (Hoffman, 2010). Most recently, Pirota *et al.* (2013) noted that bottlenose dolphin (*Tursiops truncatus*) presence in foraging areas in Aberdeen harbour declined as dredging intensity increased. Aberdeen harbour is subject to high shipping activity year round, and thus dolphins are accustomed to high levels of vessel disturbance, so in this case, it was possible for the authors to link avoidance to dredging activity, and not vessel presence in general.

Studies so far suggest that effects of dredging sound on pinnipeds may be limited. Between 2002 and 2003, during observations of dredging operations in Geraldton, Western Australia, it was reported that New Zealand fur seals (*Arctocephalus forsteri*) and Australian sea lions (*Neophoca cinerea*) showed no sign of disturbance reactions, despite the relative closeness of the dredging to popular haul-out sights (EPA, 2007). Similarly, Hawaiian monk seals (*Monachus schauinslandi*) showed no adverse reactions to bucket dredgers around Tern Island (Gilmartin, 2003). Anderwald *et al.* (2013) found that grey seals (*Halichoerus grypus*) showed some level of avoidance to high construction vessel traffic in Ireland, although it should be noted that observations were undertaken from a cliff, so animals possibly taking advantage of increased food close to operating dredgers may have been missed by observers.

Comparisons of various noise measurements with behavioural hearing data of the West Indian manatee (*Trichechus manatus*) by Gerstein *et al.* (2006) found that cavitation from dredger propellers, dredger head vacuuming, and noise from submerged slurry pipelines could mask the noise of other boats, increasing chances of ship strikes. Avoidance reactions from sirenians have also been observed during research into low-frequency noise, with Florida manatees (*T. manatus latirostris*) found to select seagrass (*Thalassia testudinum*, *Syringodium filiforme*, *Halodule wrightii*) bed sites with less low-frequency noise (Miksis-Olds *et al.*, 2007).

In conclusion, it is difficult to elucidate specific dredging noise effects on marine mammals, given that many industrial activities occur concurrently. It can be concluded that most effects concern short, perhaps medium-term behavioural reactions and masking of low-frequency calls in baleen whales and seals. Temporary hearing loss is possible if receivers stay for extended periods near the dredger, but auditory injury is unlikely.

Turbidity

Seabed disturbance through extraction, rejection, and disposal of sediments, along with outwash of excess materials, can result in

increased turbidity and creation of sediment plumes. Sediment plumes have the ability to extend the impact of dredging over larger areas that would otherwise remain unaffected physically (Hitchcock and Bell, 2004). Research has shown that effects are short lived generally, lasting a maximum of four to five tidal cycles (Hitchcock and Bell, 2004), and are confined mainly to an area of a few hundred metres from the point of discharge (Newell *et al.*, 1998; Hitchcock and Bell, 2004).

Marine mammals often inhabit turbid environments and many utilize sophisticated sonar systems to sense the environment around them (see Au *et al.*, 2000). Evidence that turbidity affects cetaceans or sirenians directly is not evident in the literature, and feeding methods employed by some mysticetes, for example, grey whales and sirenians, create plumes of sediment, indicating that individuals must have some level of tolerance and are able to feed in turbid conditions.

Researchers have explored the effects of turbidity on pinnipeds, which are not known to produce sonar for prey detection purposes. If vision is used to locate prey, increases in turbidity could affect their ability to hunt. In a captive environment, Weiffen *et al.* (2006) tested the visual acuity of harbour seals to increasing levels of turbidity, finding that it decreased substantially, as turbidity increased above 1 formazin turbidity unit (FNU). The same study tested turbidity levels in areas of the North Sea where harbour seals are known to reside; levels ranged from 7 to 40 FNU at a depth of 2 m; however, it is likely that other senses are used instead of, or in combination with, vision (e.g. Dehnhardt *et al.*, 2001). Newby *et al.* (1970) reported apparent blindness, identified by opaque and white corneas, in three harbour seals (*Phoca vitulina*) on Gertrude Island, Puget Sound, Washington. It was suggested that, as blind individuals appeared healthy, their ability to forage was unaffected by blindness. Factors used to make assumption of healthiness are not, however, explained. Similar assumptions were made by McConnell *et al.* (1999), who used satellite relay data loggers (SRDLs) to track foraging areas and trip durations of grey seals in the North Sea. One blind seal was included in the study, but no significant difference in foraging behaviour was found. These results indicate that vision is not essential to pinnipeds' survival, or ability to forage.

To summarize, the limited available information indicates that increased turbidity, as a result of dredging, is unlikely to have a substantial direct impact on marine mammals that often inhabit naturally turbid or dark environments. This is likely because other senses are utilized, and vision is not relied upon solely.

Indirect impacts

Indirect impacts on marine mammals from dredging stem from changes to their physical environment, or to their prey. Physical characteristics, such as topography, depth, waves, tidal currents, sediment particle size, and suspended sediment concentrations, are altered by dredging (see review by Tillin *et al.*, 2011), but changes also occur naturally, as a result of disturbance events such as tides, waves, and storms. Consequently, small changes are unlikely to have a substantial effect on the marine ecosystem, and can even increase biodiversity, but large-scale repeated alterations have the potential to affect the entire foodweb, right up to marine mammals.

Indirect effects can be positive or negative, but are most likely highly species-specific, so it is unclear how effects from dredging influence various marine organisms. Given the varied and vast quantity of data on the subject, literature reviews are not exhaustive, but the aim here is to provide a good indication of how effects of

dredging on the marine environment, fauna, and flora may affect marine mammals indirectly, although the high level of site, and species specificity, means assessment of impacts are somewhat subjective.

Negative

Dredging impacts marine organisms negatively through entrainment, habitat degradation, noise, remobilization of contaminants, sedimentation, and increases in suspended sediment concentrations.

Entrainment

All marine organisms associated with the seabed are at risk from entrainment, which is the unintentional removal of organisms by the suction field created by hydraulic dredgers (Reine and Clarke, 1998). At present, no studies address the indirect effects of entrainment on marine mammals specifically, but impacts of entrainment during marine dredging on prey species have been addressed, although mostly in unpublished, non-peer reviewed reports (see reviews by Reine and Clarke, 1998; Nightingale and Simenstad, 2001).

Entrainment rates depend on a number of factors, including depth, dredger type, speed, and strength of suction field. For example, hydraulic dredgers create stronger suction fields than mechanical ones, so are more of a risk to marine life (Reine and Clarke, 1998; Nightingale and Simenstad, 2001). Susceptibility also depends on species. Benthic fauna and demersal fish that are associated strongly with bottom substrates are considered more at risk from entrainment than highly mobile species. Overall, consensus within the literature appears that, entrainment of adult fish and many shellfish species, has minimal population level effects (Reine and Clarke, 1998; Drabble, 2012b).

In agreement with freshwater studies (e.g. Boysen and Hoover, 2009; Hoover *et al.*, 2009, 2011), dredging-related entrainment is considered to be more of an issue for young fish, and eggs and larvae of marine organisms, as their reduced swimming ability means they are unable to actively avoid the suction field (Reine and Clarke, 1998; Nightingale and Simenstad, 2001; Drabble, 2012b). Consequently, dredging in spawning areas can affect survival rate of organisms to adulthood, and therefore population structure and growth. Populations of common sole (*Solea solea*), lemon sole (*Microstomus kitt*), thickback sole (*Microchirus variegatus*), and European plaice (*Pleuronectes platessa*) in the Eastern Channel Region of the UK were monitored by Drabble (2012a) from 2005 to 2008. Baseline data were obtained in 2005, and dredging commenced in 2006. Results indicate a reduction in numbers, and a change in population structure. For example, an abundance of age 1 sole was evident in 2005, but in 2006, few age 2 sole were recorded. In 2008, fish born before dredging dominated samples. Similar results were found for plaice. Natural conditions alone could not account for the alteration, and entrainment was considered a factor, but its role is primarily unknown.

Given that effects are greatest during the egg and larval stages, impacts can be reduced by implementing temporal restrictions on dredging activity, known as environmental windows, which ensure activity is restricted in spawning and nursery grounds at critical times. To put into context of marine mammals, if risk assessments are carried out before dredging, and activities are well managed, reduction in prey numbers is unlikely to be high enough to have substantial population-level impacts.

Habitat degradation

Ecologically important habitats such as seagrass beds and coral reefs that are particularly sensitive to change are at high risk from dredging. Main concerns are physical removal, smothering, and a decrease in light intensity (Erftemeijer and Lewis, 2006; Erftemeijer et al., 2012). Losses of these habitats, as a result of dredging can be substantial. For example, a review of 45 case studies worldwide found that 21 023 ha of seagrass beds were lost as a result of 26 dredging projects over a 50-year period (Erftemeijer and Lewis, 2006), and this is likely an underestimation, as other projects were carried out where extent of loss was not reported (Erftemeijer and Lewis, 2006). Dredging impacts on seagrass beds and coral reefs have been reviewed by Erftemeijer and Lewis (2006) and Erftemeijer et al. (2012), respectively.

Seagrass beds are utilized frequently by marine mammals, but impact removal varies considerably. Herbivorous sirenians are reliant entirely on seagrass beds as a food source, so removal can have substantial effects on survival, distribution, and feeding habits (Spain and Heinsohn, 1973 cited in Heinsohn and Spain, 1974; Heinsohn et al., 1977; Marsh et al., 1982; Preen and Marsh, 1995; GBRMPA, 2011). Other species, for example, bottlenose dolphins, feed on prey within seagrass beds (e.g. Scott et al., 1990; Shane, 1990), but are not restricted to them. In fact, Allen et al. (2001) stated that bottlenose dolphins in Clearwater, Florida, preferred non-seagrass habitats, suggesting that seagrasses may create an obstruction which could hinder prey location and capture. Prey sizes were also bigger outside of seagrass habitats, so more energetically viable. Irrespective of this, seagrass beds are an essential part of ecosystems, given their primary productivity, and role in nutrient cycling and sediment stabilization (Duarte, 2002; Orth et al., 2006). They also support diverse marine communities, and their structure provides shelter for juvenile marine organisms (e.g. Heck et al., 2003). Changes therefore affect the foodweb at some level, for varying amounts of time, and ability to recover depends on species and extent of loss or damage (Erftemeijer and Lewis, 2006). In terms of smothering, burial depth, sediment type, nutrient load, and whether or not the sediment contains pollutants all influence survival (Zieman and Zieman, 1989; Wilber et al., 2005; Erftemeijer and Lewis, 2006).

Dredging-related impacts on seagrasses reported in recent years have declined generally when compared with the past (Erftemeijer and Lewis, 2006). This is perhaps the result of increased knowledge, the ability to model and predict paths of sediment plumes, and introduction of well-designed and implemented mitigation measures (Erftemeijer and Lewis, 2006). In addition, seagrasses have varying abilities to withstand at least small changes in their environment, which occur as a result of natural processes and anthropogenic activities. Thus, short-term light reductions, or thin smothering from dredging should have only short-term effects. What is clear from the research is that each case needs to be assessed individually. As long as criteria that amalgamate all factors are used during planning stages, impacts of dredging on seagrasses should be short-term, and not sufficient to have detrimental impacts on marine mammals, although minor alterations to prey availability, or distributions may occur.

Noise levels

Sound is utilized by many marine organisms to sense the environment around them and find prey. Consequently, an increase in anthropogenic low-frequency noise, such as that produced by

dredging, has the potential to cause adverse effects. The extent to which effects disseminate through the foodweb to marine mammals is unknown, but speculated effects are given, based on available data.

Extensive variability exists between hearing sensitivity of fish species, but in general, they are sensitive to low frequencies (Popper et al., 2003; Popper and Fay, 2011), which puts them at risk from dredging noise. Some level of TTS has been reported in freshwater and marine fish exposed to low-frequency white noise (e.g. Scholik and Yan, 2001; Amoser and Ladich, 2003; Smith et al., 2004a, b) and vessel noise (e.g. Scholik and Yan, 2002; Codarin et al., 2009) in laboratory experiments. Results suggest that those with more specialized hearing experience a greater level of hearing loss. It should be noted, however, that these experiments did not focus on dredging noise, so noise characteristics and exposure durations likely vary from those experienced during dredging activities, which may alter the chance and extent of TTS.

No study has looked at dredging noise specifically, but avoidance of low-frequency vessel noise by some fish species has been reported (e.g. Mitson, 1995; Mitson and Knudsen, 2003; de Robertis and Wilson, 2011; reviewed by de Robertis and Handegard, 2013) and Handegard et al. (2003) noted vertical and horizontal avoidance by cod (*Gadus morhua*) of a bottom-trawling vessel. Perhaps noise is not the primary factor causing avoidance reactions, although other factors, such as the presence of vessels themselves, may still be relevant to dredging. Small-scale avoidance of noise is unlikely to have any long-lasting effects on fitness, but if noise was to occur in breeding or feeding grounds, then fish could relocate to other areas; more research is required to assess this possibility. Other behavioural effects include increased motility (Buscaino et al., 2010), reduced feeding efficiency (Voellmy et al., 2014), and masking of communication signals (Codarin et al., 2009).

Noise also has the ability to impact larval organisms that use sounds to orientate towards settlement locations (Simpson et al., 2010; Radford et al., 2011; Holles et al., 2013). Masking of these sounds could prevent larvae settling in ideal locations, or prevent them from finding a place to settle at all (e.g. Simpson et al., 2010, 2011; Holles et al., 2013).

Responses to particle motion of low-frequency sound have also been recorded in cephalopods (*Sepia officinalis*, *Loligo vulgaris*, *Loligo pealeii*, *Octopus vulgaris*, *Illex coindetii*; Packard et al., 1990; Mooney et al., 2010), which can form an important part of the diet of some marine mammals. Low-frequency noise in the 1 Hz–10 kHz band altered cephalopod breathing rhythms and movement, and in some cases induced acoustic trauma and permanent damage to statocysts' sensory hair cells (Packard et al., 1990; Andre et al., 2011; Solé et al., 2013), that are responsible for the detection of sound (Kaifu et al., 2008; Mooney et al., 2010).

Dredging noise is unlikely to result in direct mortality, or permanent hearing damage of fish, but long-term exposure could theoretically affect fitness of some individuals. Exclusion of prey from foraging areas has potential to impact marine mammals negatively, but extent to which this occurs depends on the significance of the feeding ground, ability to switch prey species, and availability of alternative foraging areas. The level of effect is therefore species- and context-dependent.

Toxins and pollutants

Over time, sediments accumulate toxins and pollutants such as hydrocarbons and heavy metals (Cundy et al., 2003; Taylor et al., 2004). Dredging disturbance of sediments can release contaminants

into the water column, which has the potential to change chemical properties of the sediment, and reduce water quality at both extraction and dumping sites for some time after dredging has ceased. Once suspended, contaminants can become available to marine organisms, and potentially accumulate up the food chain. Remobilization and bioavailability of contaminants is site-specific, complex, and affected by a multitude of factors. The fate of remobilized contaminants has not been discussed here, but see reviews by Eggleton and Thomas (2004) and Roberts (2012) for details. Literature on dredging release of contaminants suggests that remobilization is restricted in both time and space, and that as long as highly contaminated sediments are managed strictly, concentrations are not high enough to have detrimental effects on the environment (Roberts, 2012).

Marine mammals are susceptible to bioaccumulation because they feed at high trophic levels, and have a large proportion of lipid-rich blubber which accumulates contaminants readily (Vos *et al.*, 2003). High contaminant levels have been linked to immune system depression, disease breakouts, reproductive effects, developmental effects, and endocrine disruption (see Vos *et al.*, 2003 for a review of toxins and marine mammals).

Dredging release of contaminants may increase the amount consumed by lower trophic levels, including species of marine mammal prey, but laboratory studies indicate that effects on marine organisms are varied and dependent on conditions, such as concentration, exposure duration, and species (Rice and White, 1987; Fichet *et al.*, 1998; Hedge *et al.*, 2009; Knott *et al.*, 2009; reviewed by Roberts, 2012). Negative impacts do, however, have the potential to reduce prey availability.

Marine mammals accumulate high levels of contaminants irrespective of whether dredging occurs. Linking remobilization of contaminants from dredging to effects in marine mammals is challenging. Levels of toxins in blubber before, during, and after dredging are unknown, marine mammals are mobile and exposed to contaminants throughout their entire range, and effects are only likely to be discovered long after dredging ceases. Risks are highest and impacts greatest, when dredging contaminated sediments, but screening ensures they are disposed of responsibly, and not in the open ocean (Roberts, 2012). Although organisms can accumulate contaminants released during dredging for months after it has ceased, lethal effects are unusual and likely to be confined spatially.

Suspended sediment

Natural events, such as storms that disturb sediments, increase turbidity. To cope, marine organisms have evolved varying levels of tolerance, or survival mechanisms; however, dredging-related increases in turbidity may exceed natural levels, or vary in terms of timing, which can put strain on some organisms' ability to survive. Impacts of increased suspended sediment concentrations are highly species-specific, and vary with sediment characteristics (see reviews by Stern and Stickle, 1978; Newcombe and Macdonald, 1991; Clark and Wilber, 2000; Wilber and Clarke, 2001; Berry *et al.*, 2003).

Considerable research has been carried out to assess impacts of suspended sediments on marine organisms, but not all studies have used sediment plume concentrations that resemble those produced during dredging. This means application to dredging is limited, although large variations do exist in plume concentrations because of local conditions (and dredger type). van der Veer (1979) cited in van der Veer *et al.* (1985) recorded suspended sediment concentrations of 6300 mg l⁻¹ in the outwash of a suction dredger, while Hitchcock and Dearnaley (1996) reported lower

concentrations of 80–340 mg l⁻¹ (upper water column) and 480–611 mg l⁻¹ (lower water column) within 100 m of a dredger. Levels reported by Hitchcock and Bell (2004) were in-between at 5500 mg l⁻¹ close to a dredger, reducing to 450 mg l⁻¹ with distance, and Reine *et al.* (2007) stated that maximum concentrations, recorded in proximity to a bucket dredger in Maumee Bay, were 800 mg l⁻¹, although levels decreased rapidly, and were closer to 300 mg l⁻¹ at a distance of 24 m.

Turbidity has the potential to impact fish feeding ability, although piscivorous fish that feed on larger prey, detected visually over longer distances, are affected to a greater extent than planktivorous fish, that detect prey visually over short distances (Hecht and van der Lingen, 1992; Utne-Palm, 2002; de Robertis *et al.*, 2003). Other behavioural alterations include changes in habitat choice (e.g. Wenger and McCormick, 2013), altered predator–prey relationships (e.g. Wenger *et al.*, 2013), and increased anti-predator responses (Leahy *et al.*, 2011). High suspended sediments can also cause gill damage in fish (Herbert and Merckens, 1961; Lake and Hinch, 1999; Au *et al.*, 2004; Wong *et al.*, 2013).

Increases in suspended sediment concentrations on invertebrates include abrasion, decreased respiration rates due to clogging of filtration mechanisms, or behavioural alterations. Change in conditions can also affect feeding efficiency of filter-feeders, as the food-to-sediment-ratio is decreased, meaning more energy is required to sort through additional material. Reactions are, as expected, species-specific, but Last *et al.* (2011) stated that changes in behaviours observed in blue mussels (*Mytilus edulis*), queen scallops (*Aequipecten opercularis*), Ross worms (*Sabellaria spinulosa*), and edible crabs (*Cancer pagurus*) exposed to suspended sediment concentrations of 12 and 71 mg l⁻¹ have the potential to impact fitness, if conditions are prolonged; however, lethal effects were not observed for either concentration.

The impact of suspended sediment on eggs and larvae of marine organisms has been addressed in many studies under laboratory conditions (e.g. Auld and Schubel, 1978; Kiørboe *et al.*, 1981; Morgan *et al.*, 1983; Griffin *et al.*, 2009; Suedel *et al.*, 2012). Auld and Schubel (1978) and Kiørboe *et al.* (1981) suggest that suspended sediment concentrations have limited effects on egg hatching success, but exposure was not immediate following dispersal. Griffin *et al.* (2009), on the other hand, found that if Pacific herring (*Clupea pallasii*) eggs were exposed to suspended sediments of 250 and 500 mg l⁻¹, within 2 h of dispersal, sediments adhered to the outside of eggs, which led to increased egg-to-egg attachment, and abnormal larval development; ability to attach to surfaces could also be compromised. Outside of the initial 2 h, no significant effect was recorded. The majority of data are collected in laboratories under set conditions that vary from those in the wild; current strength, temperature, and contaminant levels may all have an effect. Effects also vary substantially depending on species, for example, not all species' eggs form an adhesive layer, which influences how sediment particles attach to the outside.

Modelling of sediment plumes can predict where concentrations will be highest, meaning dredging can be planned to avoid sensitive areas, and times such as spawning. If this is the case, lethal and long-lasting impacts on marine organisms should be minimized, but small-scale or short-term effects are to be expected, although they are unlikely to have significant impacts on marine mammals.

Sedimentation

Change in sediment structure as a result of dredging has been reported frequently in the literature (e.g. Kenny and Rees, 1996;

Desprez, 2000; van Dalftsen *et al.*, 2000; Weller *et al.*, 2002; Hitchcock and Bell, 2004; Boyd *et al.*, 2005; Cooper *et al.*, 2005; Robinson *et al.*, 2005; Desprez *et al.*, 2010; Barrio Froján *et al.*, 2011); a fining of the sediment is most common, especially where screening is carried out. Extent of change, and ability to recover, varies substantially, and depends on area, and type of sediment deposited. In general, regularly disturbed habitats characterized by fine sands and fast-growing opportunistic species are affected less, and recover quicker, than stable habitats monopolized by coarse gravels and slow-growing sessile fauna and flora (Tillin *et al.*, 2011). Coarse sediment habitats are also likely to see a greater change in species composition over the long term, as the new finer sediment suits a different range of species than those that occupied the coarser sediments, although it should be noted that sediment composition is not the only driver in determining benthic community composition; other factors have impacts.

In addition to changing community structure, sediment deposition can smother or bury marine organisms associated with the seabed. Non-mobile organisms and early life stages that are unable to move out of the path of dredgers are most at risk. Impacts are highly species-specific and depend on a species' ability to either tolerate or escape burial, both of which vary with sediment characteristics and temperature. This variation is demonstrated by Last *et al.* (2011) through laboratory experiments on a number of species. Some can survive prolonged periods buried in the sediments (e.g. Ross worm), while others suffer high mortality if buried, but are able to emerge from relatively deep sediments [e.g. green sea urchin (*Psammechinus miliaris*)]. Species that form large beds, for example, oysters, are important within the ecosystem as many organisms rely on or are associated with them for colonization or predator protection (Wilber *et al.*, 2005).

Smothering of eggs can cause mass mortality, delayed hatching (see, for example, Berry *et al.*, 2011), or added sediment could reduce the number of settlement locations available to larvae, which increases level of competition (see review by Wilber *et al.*, 2005).

Given that effects of sedimentation vary massively, putting them into context of potential indirect impacts on marine mammals is challenging, although a reduction in the health of benthic communities signifies a reduction in the amount of food available to higher trophic levels, including marine mammals. Avoidance of spawning or nursery areas during dredging is beneficial, and minimizes large-scale losses of species, as will minimizing dredging-related sedimentation around oyster beds or other sensitive habitats. Nevertheless, sedimentation will have some level of impact on marine organisms, and could result in mortality or long-term changes in the environment; however, dredged areas are colonized quickly by opportunistic species, which likely attract higher trophic level species. If re-colonization includes those species consumed by marine mammals, then impact on prey availability should be short-term only, in which case long-lasting, population-level effects are unlikely, but short-term changes to feeding, or distribution are possible.

Positive

Dredging disturbance of sediments has been reported to enhance diversity and abundance of benthic fauna near dredged channels (Jones and Candy, 1981; Poiner and Kennedy, 1984; van Dalftsen and Essink, 2001; Newell *et al.*, 2004; Claveleau and Desprez, 2009). A possible reason for this enhancement is the release of organic nutrients from the sediment plume (Ingle, 1952; Biggs,

1968; Sherk, 1972; Oviatt *et al.*, 1981; Walker and O'Donnell, 1981). This rise in species abundance has the potential to increase the amount of food available temporarily to marine mammals. For example, Anderwald *et al.* (2013) reported larger numbers of bottlenose dolphins during construction activity around Doonanierin Point, Ireland. It cannot be said with certainty that increased prey numbers, as a result of seabed disturbance, attracted the dolphins, as other factors were not explored, but it is a possibility.

Change in topography could also affect marine mammals positively. For example, Allen *et al.* (2001) found that bottlenose dolphins in Anclote Key, Clearwater, Florida, favour previously dredged channels, over other habitat types, stating that the dolphins used the structural features to aid in prey detection and capture.

In terms of marine organisms, increase in food availability can result in increased growth rates. For example, Ingle (1952) reported that oyster species grew quicker in areas of high turbidity. Some fish larvae also benefit, as Boehlert and Morgan (1985) reported that at suspended sediment concentrations of 500–1000 mg l⁻¹, feeding rate of larval Pacific herring was increased significantly above the control (0 mg l⁻¹). Increased turbidity could also increase protection against visual predators, which will find it harder to hunt. Positive effects are often observed only up to a certain concentration, so perhaps extensive dredging could increase suspended sediment concentrations above those that appear positive, and negative effects will resume.

Increases are often short-lived only, and followed by reductions in diversity, biomass, and abundance. Thus, positive effects can be limited, and potentially harmful if marine mammals are attracted to areas of high human activity, where the risk of collision is increased, as is exposure to noise.

Conclusions

There are few studies on the effects of dredging on marine mammals that can be attributed entirely to dredging activities in isolation.

In terms of direct effects on marine mammals, collisions are possible, but improbable given that operating dredgers are either stationary or moving at slow speeds. Dredging noise levels vary greatly, depending not only on dredging methods used, but also on disparities in each method. Limited data that do exist highlight that dredging is unlikely to cause physiological damage to marine mammal auditory systems, but is more likely to lead to masking and behavioural disturbances, and baleen whales could be more at risk than other taxa. Effects of turbidity are often localized with minimal direct impact on marine mammals that inhabit naturally turbid and dark environments.

Indirect effects of dredging on marine mammals are more complex, and considerably less well understood, but studies on potential marine mammal prey species are more numerous. In general, the literature suggests that dredging causes reductions in biomass, abundance, and species diversity for varying lengths of time, depending on surrounding conditions. Marine mammals can likely compensate for small-scale changes in prey abundance by switching prey species, moving to alternative foraging grounds, or increasing time spent foraging, although this maybe more of an issue for small, restricted populations, as movement away from areas of high disturbance may not be possible.

Entrapment in nursery or spawning grounds of prey could cause significant reductions in prey abundance, as could removal of, or damage to, sensitive seagrass systems. No studies have addressed the impact of dredging noise on fish, but research on low-frequency

noise exposure suggest that TTS is possible, although avoidance and masking are more likely.

Disturbance of sediments pose some of the greatest risks to marine environments. Remobilization of contaminants can increase uptake by marine organisms, which will disseminate through the foodweb to marine mammals, but effects are usually localized and contaminated sediments disposed of elsewhere. Increased suspended sediment concentrations, and sedimentation can result in long-term loss or permanent changes to the seabed, but negative impact on marine mammals may be reduced if the new species serve the same purpose, and occupy the same trophic levels as those that occupied the habitat before dredging.

Effects of dredging can be positive, due to increased primary production and nutrient enrichment from sediment dispersal and entrainment. Increases in populations are, however, often short term and recovery of habitats to pre-disturbance conditions can take years.

Adverse impacts from dredging can be limited by implementing mitigation measures, such as the use of environmental windows which ensure that dredging activities do not occur in important habitats or at times when marine mammals or their prey are most sensitive, for example, during breeding or spawning seasons. More likely effects include masking, avoidance and short-term changes to behaviour, and prey availability. Context is however important when discussing impacts, because marine mammals are more likely to tolerate disturbance, and remain near active dredgers, if in a prime foraging location, where rewards are high. In this case, reactions may not be obvious to observers, but the absence of a measurable response does not mean longer-term impacts are absent.

Supplementary data

Supplementary material is available at the *ICESJMS* online version of the manuscript.

References

- Allen, M. C., Read, A. J., Gaudet, J., and Sayigh, L. S. 2001. Fine-scale habitat selection of foraging bottlenose dolphins *Tursiops truncatus* near Clearwater, Florida. *Marine Ecology Progress Series*, 222: 253–264.
- Amoser, S., and Ladich, F. 2003. Diversity in noise-induced temporary hearing loss in otophysine fishes. *Journal of the Acoustical Society of America*, 113: 2170–2179.
- Anderwald, P., Brandecker, A., Coleman, M., Collins, C., Denniston, H., Haberlin, M. D., Donovan, M., *et al.* 2013. Displacement responses of a mysticete, an odontocete, and a phocid seal to construction-related vessel traffic. *Endangered Species Research*, 21: 231–240.
- Andre, M., Sole, M., Lenoir, M., Durfort, M., Quero, C., Mas, A., Lombarte, A., *et al.* 2011. Low-frequency sounds induce acoustic trauma in cephalopods. *Frontiers in Ecology and the Environment*, 9: 489–493.
- Au, D. W. T., Pollino, C. A., Wu, R. S. S., Shin, P. K. S., Lau, S. T. F., and Tang, J. Y. M. 2004. Chronic effects of suspended solids on gill structure, osmoregulation, growth, and triiodothyronine in juvenile green grouper *Epinephelus coioides*. *Marine Ecology Progress Series*, 266: 255–264.
- Au, W. W. L., Popper, A. N., and Fay, R. R. 2000. Hearing by whales and dolphins. *Springer Handbook of Auditory Research*. Springer-Verlag, New York.
- Auld, A. H., and Schubel, J. R. 1978. Effects of suspended sediment on fish eggs and larvae: a laboratory assessment. *Estuarine and Coastal Marine Science*, 6: 153–164.
- Barrio Froján, C. R. S., Cooper, K. M., Bremner, J., Defew, E. C., Wan Hussin, W. M. R., and Paterson, D. M. 2011. Assessing the recovery of functional diversity after sustained sediment screening at an aggregate dredging site in the North Sea. *Estuarine, Coastal and Shelf Science*, 92: 358–366.
- Berry, W., Rubinstein, N., Melzian, B., and Hill, B. 2003. The biological effects of Suspended and Bedded Sediment (SABS) in aquatic systems: a review. US Environment Protection Agency. 58 pp.
- Berry, W. J., Rubinstein, N. I., Hinchey, E. K., Klein-MacPhee, G., and Clarke, D. G. 2011. Assessment of dredging-induced sedimentation effects on winter flounder (*Pseudopleuronectes americanus*) hatching success: results of laboratory investigations. Western Dredging Association Technical Conference and Texas A&M Dredging Seminar, pp. 47–57. Nashville, TN.
- Best, P., Peddemors, V. M., Cockcroft, V. G., and Rice, N. 2001. Mortalities of right whales and related anthropogenic factors in South African waters, 1963–1998. *Journal of Cetacean Research and Management*, (Special Issue) No. 2: 171–176.
- Biggs, R. B. 1968. Environmental effects of overboard spoils disposal. *Journal of the Sanitary Engineering Division*, 94: 477–488.
- Boehlert, G. W., and Morgan, J. B. 1985. Turbidity enhances feeding abilities of larval Pacific herring *Clupea harengus pallasii*. *Hydrobiologia*, 123: 161–170.
- Boyd, S. E., Limpenny, D. S., Rees, H. L., and Cooper, K. M. 2005. The effects of marine sand and gravel extraction on the macrobenthos at a commercial dredging site (results 6 years post-dredging). *ICES Journal of Marine Science*, 62: 145–162.
- Boysen, K. A., and Hoover, J. J. 2009. Swimming performance of juvenile white sturgeon (*Acipenser transmontanus*): training and the probability of entrainment due to dredging. *Journal of Applied Ichthyology*, 25: 54–59.
- Brunn, P., Gayes, P. T., Schwab, W. C., and Eiser, W. C. 2005. Dredging and offshore transport of materials. *Journal of Coastal Research*, (Special Issue) No. 2: 453–525.
- Bryant, P. J., Lafferty, C. M., and Lafferty, S. K. 1984. Reoccupation of Laguna Guerrero Negro, Baja, California, Mexico by gray whales. *In* The Gray Whale, *Eschrichtius robustus*, pp. 375–386. Ed. by M. L. Jones, S. L. Swartz, and S. Leatherman. Academic Press, Orlando, FL, USA.
- Buscaino, G., Filiciotto, F., Buffa, G., Bellante, A., Stefano, V. D., Assenza, A., Fazio, F., *et al.* 2010. Impact of an acoustic stimulus on the motility and blood parameters of European sea bass (*Dicentrarchus labrax* L.) and gilthead sea bream (*Sparus aurata* L.). *Marine Environmental Research*, 69: 136–142.
- CEDA. 2011. Underwater sound in relation to dredging. Central Dredging Association (CEDA), CEDA position paper, 7 November 2011. 6 pp.
- Chilvers, B. L., Lawler, I. R., Macknight, F., Marsh, H., Noad, M., and Paterson, R. 2005. Moreton Bay, Queensland, Australia: an example of the co-existence of significant marine mammal populations and large-scale coastal development. *Biological Conservation*, 122: 559–571.
- Clark, C. W., Ellison, W. T., Southall, B. L., Hatch, L., Van Parijs, S. M., Frankel, A., and Ponirakis, D. 2009. Acoustic masking in marine ecosystems: intuitions, analysis, and implication. *Marine Ecology Progress Series*, 395: 201–222.
- Clark, D. G., and Wilber, D. H. 2000. Assessment of potential impacts of dredging operations due to sediment resuspension. US Army Engineer Research and Development Centre ERDC TN-DOER-E9. 14 pp.
- Claveleau, D., and Desprez, M. 2009. Marine aggregates in France: current production, materials, constraints experienced and expected and future development. European Marine Sand and Gravel Group—a Wave of Opportunities for the Marine Aggregates Industry, p. 6. Rome, Italy.
- Codarin, A., Wysocki, L. E., Ladich, F., and Picciulin, M. 2009. Effects of ambient and boat noise on hearing and communication in three fish species living in a marine protected area (Miramare, Italy). *Marine Pollution Bulletin*, 58: 1880–1887.

- Coll, M., Piroddi, C., Albouy, C., Lasram, F. B., Cheung, W. W. L., Christensen, V., Karpouzi, V. S., *et al.* 2012. The Mediterranean Sea under siege: spatial overlap between marine biodiversity, cumulative threats and marine reserves. *Global Ecology and Biogeography*, 21: 465–480.
- Cooper, K. M., Eggleton, J. D., Vize, S. J., Vanstaen, K., Smith, R., Boyd, S. E., Ware, S., *et al.* 2005. Assessment of the re-habilitation of the seabed following marine aggregate dredgingpart II. Cefas Science Series Technical Report, 130. 82 pp.
- Croll, D. A., Clark, C. W., Calambokidis, J., Ellison, W. T., and Tershy, B. R. 2001. Effect of anthropogenic low-frequency noise on the foraging ecology of Balaenoptera whales. *Animal Conservation*, 4: 13–27.
- Cundy, A. B., Croudace, I. W., Cearreta, A., and Irabien, M. J. 2003. Reconstructing historical trends in metal input in heavily-disturbed, contaminated estuaries: studies from Bilbao, Southampton Water and Sicily. *Applied Geochemistry*, 18: 311–325.
- de Jong, C. A. F., Ainslie, M. A., Dreschler, J., Jansen, E., Heemskerk, E., and Groen, W. 2010. Underwater noise of Trailing Suction Hopper Dredgers at Maasvlakte 2: Analysis of source levels and background noise – TNO-DV 2010 C335.
- de Robertis, A., and Handegard, N. O. 2013. Fish avoidance of research vessels and the efficacy of noise-reduced vessels: a review. *ICES Journal of Marine Science*, 70: 34–45.
- de Robertis, A., Ryer, C. H., Veloza, A., and Brodeur, R. D. 2003. Differential effects of turbidity on prey consumption of piscivorous and planktivorous fish. *Canadian Journal of Fisheries and Aquatic Sciences*, 60: 1517–1526.
- de Robertis, A., and Wilson, C. D. 2011. Silent ships do not always encounter more fish (revisited): comparison of acoustic backscatter from walleye pollock recorded by a noise-reduced and a conventional research vessel in the eastern Bering Sea. *ICES Journal of Marine Science*, 68: 2229–2239.
- Dehnhardt, G., Mauack, B., Hanke, W., and Bleckmann, H. 2001. Hydrodynamic trail-following in harbor seals (*Phoca vitulina*). *Science*, 293: 102–104.
- Desprez, M. 2000. Physical and biological impact of marine aggregate extraction along the French coast of the Eastern English Channel: short and long-term post-dredging restoration. *ICES Journal of Marine Science*, 57: 1428–1438.
- Desprez, M., Pearce, B., and Le Bot, S. 2010. The biological impact of overflowing sands around a marine aggregate extraction site: Dieppe (eastern English Channel). *ICES Journal of Marine Science*, 67: 270–277.
- Di Iorio, L., and Clark, C. W. 2012. Exposure to seismic survey alters blue whale acoustic communication. *Biological Letters*, 6: 51–54.
- Dickerson, C., Reine, K. J., and Clarke, D. G. 2001. Characterization of underwater sounds produced by bucket dredging operations. DOER Technical Notes Collection (ERDC TN-DOER-E14), US Army Engineer Research and Development Center, Vicksburg, MS. 17 pp.
- Diederichs, A., Brandt, M., and Nehls, G. 2010. Does sand extraction near Sylt affect harbour porpoises? *Wadden Sea Ecosystem*, 26: 199–203.
- Drabble, R. 2012a. Monitoring of East Channel dredge areas benthic fish population and its implications. *Marine Pollution Bulletin*, 64: 363–372.
- Drabble, R. 2012b. Projected entrainment of fish resulting from aggregate dredging. *Marine Pollution Bulletin*, 64: 373–381.
- Duarte, C. M. 2002. The future of seagrass meadows. *Environmental Conservation*, 29: 192–206.
- Eggleton, J., and Thomas, K. V. 2004. A review of factors affecting the release and bioavailability of contaminants during sediment disturbance events. *Environment International*, 30: 973–980.
- EPA. 2007. Albany port expansion proposal: public environmental review. Prepared by the Environmental Protection Agency (EPA) on behalf of the Albany Port Authority (APA). 5 pp.
- Erfteimeijer, P. L. A., and Lewis, R. R. R., III. 2006. Environmental impacts of dredging on seagrasses: a review. *Marine Pollution Bulletin*, 52: 1553–1572.
- Erfteimeijer, P. L. A., Riegl, B., Hoeksema, B. W., and Todd, P. A. 2012. Environmental impacts of dredging and other sediment disturbances on corals: a review. *Marine Pollution Bulletin*, 64: 1737–1765.
- EUDA. 2014. Types of dredger. European Dredging Association.
- Fichet, D., Radenac, G., and Miramand, P. 1998. Experimental studies of impacts of harbour sediments resuspension to marine invertebrates larvae: bioavailability of Cd, Cu, Pb and Zn and toxicity. *Marine Pollution Bulletin*, 36: 509–518.
- GBRMPA. 2011. Extreme weather and the Great Barrier Reef. Great Barrier Reef Marine Park Authority Technical Report Series. 26 pp.
- Gende, S. M., Hendrix, A. N., Harris, K. R., Eichenlaub, B., Nielsen, J., and Pyare, S. 2011. A Bayesian approach for understanding the role of ship speed in whale–ship encounters. *Ecological Applications*, 21: 2232–2240.
- Geraci, J., and Lounsbury, V. 2001. Marine mammal health: holding the balance in an ever-changing sea. *In Marine Mammals*, pp. 365–383. Ed. by P. H. Evans, and J. Raga. Springer US, New York.
- Gerstein, E. R., Blue, J. E., Pinto, G. F., and Barr, S. 2006. Underwater noise and zones of masking with respect to hopper dredging and manatees in the St. Johns River in Jacksonville. *Journal of the Acoustical Society of America*, 120: 3145–3222.
- Gilmartin, W. G. 2003. Responses of Hawaiian monk seals to human disturbance and handling. *In Workshop on the Management of Hawaiian Monk Seals on Beaches in the Main Hawaiian Islands*, p. 8. Marine Mammal Commission, National Marine Fisheries Service, Hawaii Division of Aquatic Resources, Kauai, Hawaii.
- Gordon, J., and Tyack, P. L. 2002. Sounds and cetaceans. *In Marine Mammals: Biology and Conservation*, pp. 139–196. Ed. by P. G. H. Evans, and J. A. Raga. Kluwer Academic/Plenum Press, New York.
- Greene, C. R. J. 1987. Characteristics of oil industry dredge and drilling sounds in the Beaufort Sea. *Journal of the Acoustical Society of America*, 82: 1315–1324.
- Griffin, F. J., Smith, E. H., Vines, C. A., and Cherr, G. N. 2009. Impacts of suspended sediments on fertilization, embryonic development, and early larval life stages of the Pacific herring, *Clupea pallasii*. *The Biological Bulletin*, 216: 175–187.
- Handegard, N. O., Michalsen, K., and Tjøstheim, D. 2003. Avoidance behaviour in cod (*Gadus morhua*) to a bottom-trawling vessel. *Aquatic Living Resources*, 16: 265–270.
- Hecht, T., and van der Lingen, C. D. 1992. Turbidity-induced changes in feeding strategies of fish in estuaries. *South African Journal of Zoology*, 27: 95–107.
- Heck, K. L., Jr, Hays, G., and Orth, R. J. 2003. Critical evaluation of the nursery role hypothesis for seagrass meadows. *Marine Ecology Progress Series*, 253: 123–136.
- Hedge, L. H., Knott, N. A., and Johnston, E. L. 2009. Dredging related metal bioaccumulation in oysters. *Marine Pollution Bulletin*, 58: 832–840.
- Heinsohn, G. E., and Spain, A. V. 1974. Effects of a tropical cyclone on littoral and sublittoral biotic communities and on a population of dugongs (*Dugong dugon* (Müller)). *Biological Conservation*, 6: 143–152.
- Heinsohn, G. E., Wake, J., Marsh, H., and Spain, A. V. 1977. The dugong (*Dugong dugon* (Müller)) in the seagrass system. *Aquaculture*, 12: 235–248.
- Herbert, D. W. M., and Merckens, J. C. 1961. The effect of suspended mineral solids on the survival of trout. *International Journal of Air and Water Pollution*, 5: 46–55.
- Hitchcock, D. R., and Bell, S. 2004. Physical impacts of marine aggregate dredging on seabed resources in coastal deposits. *Journal of Coastal Research*, 20: 101–114.

- Hitchcock, D. R., and Dearnaley, M. P. 1996. Investigation of benthic and surface plumes associated with marine aggregates mining in the United Kingdom. *In* The Global Ocean—Towards Operational Oceanography Volume 2. Proceedings of the Oceanology International Conference.
- Hoffman, C. 2010. Mitigating impacts of underwater noise from dredging on beluga whales in Cook Inlet, Alaska. *In* 2nd International Conference on the Effects of Noise on Aquatic Marine Life, p. 5. Cork, Ireland.
- Holles, S., Simpson, S. D., Radford, A. N., Berten, L., and Lecchini, D. 2013. Boat noise disrupts orientation behaviour in a coral reef fish. *Marine Ecology Progress Series*, 485: 295–300.
- Hoover, J. J., Boysen, K. A., Beard, J. A., and Smith, H. 2011. Assessing the risk of entrainment by cutterhead dredges to juvenile lake sturgeon (*Acipenser fulvescens*) and juvenile pallid sturgeon (*Scaphirhynchus albus*). *Journal of Applied Ichthyology*, 27: 369–375.
- Hoover, J. J., Turnage, A., and Killfore, J. 2009. Swimming performance of juvenile paddlefish: quantifying risk of entrainment. *American Fisheries Society Symposium*, 66: 1–15.
- IADC. 2012. Dredging in Figures. International Association of Dredging Companies. 9 pp.
- Ingle, R. M. 1952. Studies on the effect of dredging operations upon fish and shellfish. State of Florida Board of Conservation. 25 pp.
- Jensen, A. S., and Silber, G. K. 2003. Large whale ship strike database. US Department of Commerce, National Oceanic and Atmospheric Administration (NOAA) NOAA Technical Memorandum. NMFS-OPR. 37 pp.
- Jones, G., and Candy, S. 1981. Effects of dredging on the macrobenthic infauna of Botany Bay. *Australian Journal of Marine and Freshwater Research*, 32: 379–398.
- Kaifu, K., Akamatsu, T., and Segawa, S. 2008. Underwater sound detection by cephalopod statocyst. *Fisheries Science*, 74: 781–786.
- Kastak, D., Southall, B., Schusterman, R. J., and Kastak, C. R. 2005. Underwater temporary threshold shift in pinnipeds: effects of noise level and duration. *Journal of the Acoustical Society of America*, 118: 3154–3163.
- Kastelein, R. A., Gransier, R., Hoek, L., and Olthuis, J. 2012. Temporary threshold shifts and recovery in a harbor porpoise (*Phocoena phocoena*) after octave-band noise at 4 kHz. *Journal of the Acoustical Society of America*, 132: 3525–3537.
- Kenny, A. J., and Rees, H. L. 1996. The effects of marine gravel extraction on the macrobenthos: results 2 years post-dredging. *Marine Pollution Bulletin*, 32: 615–622.
- Kjørboe, T., Frantsen, E., Jensen, C., and Sørensen, G. 1981. Effects of suspended sediment on development and hatching of herring (*Clupea harengus*) eggs. *Estuarine, Coastal and Shelf Science*, 13: 107–111.
- Knott, N. A., Aulbury, J. P., Brown, T. H., and Johnston, E. L. 2009. Contemporary ecological threats from historical pollution sources: impacts of large-scale resuspension of contaminated sediments on sessile invertebrate recruitment. *Journal of Applied Ecology*, 46: 770–781.
- Laist, D. W., Knowlton, A. R., Mead, J. G., Collet, A. S., and Podesta, M. 2001. Collisions between ships and whales. *Marine Mammal Science*, 17: 35–75.
- Lake, R. G., and Hinch, S. G. 1999. Acute effects of suspended sediment angularity on juvenile coho salmon (*Oncorhynchus kisutch*). *Canadian Journal of Fisheries and Aquatic Sciences*, 56: 862–867.
- Lammers, M. O., Pack, A. A., Lyman, E. G., and Espiritu, L. 2013. Trends in collisions between vessels and North Pacific humpback whales (*Megaptera novaeangliae*) in Hawaiian waters (1975–2011). *Journal of Cetacean Research and Management*, 13: 73–80.
- Last, K. S., Hendrick, V. J., Beveridge, C. M., and Davies, A. J. 2011. Measuring the effects of suspended particulate matter and smothering on the behaviour, growth and survival of key species found in areas associated with aggregate dredging. Scottish Association for Marine Science Report for the Marine Aggregate Levy Sustainability Fund, Project MEPF 08/P76. 69 pp.
- Leahy, S. M., McCormick, M. I., Mitchell, M. D., and Ferrari, M. C. O. 2011. To fear or to feed: the effects of turbidity on perception of risk by a marine fish. *Biology Letters*, 7: 811–813.
- Lucke, K., Siebert, U., Lepper, P. A., and Blanchet, M. A. 2009. Temporary shift in masked hearing thresholds in a harbor porpoise (*Phocoena phocoena*) after exposure to seismic airgun stimuli. *Journal of the Acoustical Society of America*, 125: 4060–4070.
- Marsh, H., Channells, P. W., Heinsohn, G. E., and Morrissey, J. 1982. Analysis of stomach contents of dugongs from Queensland. *Australian Wildlife Research*, 9: 55–67.
- McConnell, B. J., Fedak, M. A., Lovell, P., and Hammond, P. S. 1999. Movements and foraging areas of grey seals in the North Sea. *Journal of Applied Ecology*, 36: 573–590.
- Miksis-Olds, J. L., Donaghay, P. L., Miller, J. H., Tyack, P. L., and Nystuen, J. A. 2007. Noise level correlates with manatee use of foraging habitats. *Journal of the Acoustical Society of America*, 121: 3011–3020.
- Mitson, R. B. 1995. Underwater noise of research vessels: review and recommendations. ICES Cooperative Research Report, 209. 61 pp.
- Mitson, R. B., and Knudsen, H. P. 2003. Causes and effects of underwater noise on fish abundance estimation. *Aquatic Living Resources*, 16: 255–263.
- Mooney, T. A., Hanlon, R. T., Christensen-Dalsgaard, J., Madsen, P. T., Ketten, D. R., and Nachtigall, P. E. 2010. Sound detection by the longfin squid (*Loligo pealeii*) studied with auditory evoked potentials: sensitivity to low-frequency particle motion and not pressure. *Journal of Experimental Biology*, 213: 3748–3759.
- Mooney, T. A., Nachtigall, P. E., Breese, M., Vlachos, S., and Au, W. W. 2009. Predicting temporary threshold shifts in a bottlenose dolphin (*Tursiops truncatus*): the effects of noise level and duration. *Journal of Acoustical Society of America*, 125: 1816–1826.
- Morgan, R. P., Rasin, V. J., and Noe, L. A. 1983. Sediment effects on eggs and larvae of striped bass and white perch. *Transactions of the American Fisheries Society*, 112: 220–224.
- Nachtigall, P. E., Pawloski, J. L., and Au, W. W. 2003. Temporary threshold shifts and recovery following noise exposure in the Atlantic bottlenose dolphin (*Tursiops truncatus*). *Journal of the Acoustical Society of America*, 113: 3425–3429.
- Nedwell, J. R., Parvin, S. J., Brooker, A. G., and Lambert, D. R. 2008. Modelling and measurement of underwater noise associated with the proposed Port of Southampton capital dredge and redevelopment of berths 201/202 and assessment of the disturbance to salmon. Subacoustech Report, 805R0444.
- Neilson, J. L., Gabriele, C. M., Jensen, A. S., Jackson, K., and Straley, J. M. 2012. Summary of reported whale-vessel collisions in Alaskan waters. *Journal of Marine Biology*, 2012: 18.
- Newby, T. C., Hart, F. M., and Arnold, R. A. 1970. Weight and blindness of harbor seals. *Journal of Mammalogy*, 51: 152.
- Newcombe, C. P., and Macdonald, D. D. 1991. Effects of suspended sediments on aquatic ecosystems. *North American Journal of Fisheries Management*, 11: 72–82.
- Newell, R. C., Seiderer, L. J., and Hitchcock, D. R. 1998. The impact of dredging works in coastal waters: a review of the sensitivity to disturbance and subsequent recovery of biological resources on the sea bed. *Oceanography and Marine Biology: an Annual Review*, 36: 127–178.
- Newell, R. C., Seiderer, L. J., Simpson, N. M., and Robinson, J. E. 2004. Impacts of marine aggregate dredging on benthic macrofauna off the south coast of the United Kingdom. *Journal of Coastal Research*, 20: 115–125.
- Nightingale, B., and Simenstad, C. A. 2001. Dredging activities: marine issues. Washington State Transportation Center (TRAC) Report WA-RD 507.1 for the Washington State Transportation Commission and in cooperation with US Department of Transportation. 182 pp.

- NRC. 2005. Marine Mammal Populations and Ocean Noise—Determining When Noise Causes Biologically Significant Effects. The National Academics Press, Washington, DC.
- Orth, R. J., Carruthers, T. J. B., Dennison, W. C., Duarte, C. M., Fourqurean, J. W., Heck, K. L., Jr, Hughes, A. R., *et al.* 2006. A global crisis for seagrass ecosystems. *Bioscience*, 56: 987–996.
- OSPAR. 2009. Overview of the impacts of anthropogenic underwater sound in the marine environment. OSPAR Commission 441/2009. 134 pp.
- Oviatt, C. A., Hunt, C. D., Vargo, G. A., and Kopchynski, K. W. 1981. Simulation of a storm event in marine microcosms. *Journal of Marine Research*, 39: 605–618.
- Packard, A., Karlsen, H. E., and Sand, O. 1990. Low frequency hearing in cephalopods. *Journal of Comparative Physiology*, 166: 501–505.
- Panigada, S., Pesante, G., Zanardelli, M., Capoulade, F., Gannier, A., and Weinrich, M. T. 2006. Mediterranean fin whales at risk from fatal ship strikes. *Marine Pollution Bulletin*, 52: 1287–1298.
- Perrin, W. F., Würsig, B., and Thewissen, J. G. M. 2009. *Encyclopedia of Marine Mammals*. Academic Press, San Diego, CA, USA.
- Pirotta, E., Laesser, B. E., Hardaker, A., Riddoch, N., Marcoux, M., and Lusseau, D. 2013. Dredging displaces bottlenose dolphins from an urbanised foraging patch. *Marine Pollution Bulletin*, 74: 396–402.
- Poiner, I. R., and Kennedy, R. 1984. Complex patterns of change in the macrobenthos of a large sandbank following dredging. *Marine Biology*, 78: 335–352.
- Popov, V. V., Klishin, V. O., Nechaev, D. I., Pletenko, M. G., Rozhnov, V. V., Supin, A. Y., Sysueva, E. V., *et al.* 2011. Influence of acoustic noises on the white whale hearing thresholds. *Doklady Biological Sciences*, 440: 332–334.
- Popper, A. N., and Fay, R. R. 2011. Rethinking sound detection by fishes. *Hearing Research*, 273: 25–36.
- Popper, A. N., Fay, R. R., Platt, C., and Sand, O. 2003. Sound detection mechanisms and capabilities of teleost fishes. *In* *Sensory Processing in Aquatic Environments*, pp. 3–38. Ed. by S. P. Collin, and N. J. Marshall. Springer Verlag, New York.
- Preen, A., and Marsh, H. 1995. Responses of dugongs to large-scale loss of seagrass from Hervey Bay, Queensland, Australia. *Wildlife Research*, 22: 507–519.
- Radford, C. A., Stanley, J. A., Simpson, S. D., and Jeffs, A. G. 2011. Juvenile coral reef fish use sound to locate habitats. *Coral Reefs*, 30: 295–305.
- Reilly, G. P. 1950. The seagoing hopper dredge. *In* *International Conference on Coastal Engineering*, p. 4. Long Beach, CA.
- Reine, K., Clarke, D., and Dickerson, C. 2012a. Characterisation of Underwater Sounds Produced by a Backhoe Dredge Excavating Rock and Gravel. ERDC-TN-DOER-XXX. Department of Energy Resources, Washington DC, 29 pp.
- Reine, K., Clarke, D. G., Dickerson, C., and Pickard, S. 2007. Assessment of potential impacts of bucket dredging plumes on walleye spawning habitat in Maumee Bay, Ohio. *In* *Proceedings of the 18th World Dredging Congress (WODCON XVIII)*, pp. 619–636. Lake Buena Vista, FL.
- Reine, K. J., and Clarke, D. G. 1998. Entrainment by hydraulic dredges—a review of potential impacts. US Army Engineers Research and Development Center Technical Notes DOER-E1. 14 pp.
- Reine, K. J., Clarke, D., and Dickerson, C. 2012b. Characterization of underwater sounds produced by a hydraulic cutterhead dredge fracturing limestone rock. DOER Technical Notes Collection—erdc tn-doer-e34, US Army Engineer Research and Development Center, Vicksburg, MI. 19 pp.
- Reynolds, J. E., Perrin, W. F., Reeves, R. R., Montgomery, S., and Ragen, T. 2005. *Marine Mammal Research—Conservation Beyond Crisis*. John Hopkins University Press, Baltimore, MD.
- Rice, C. P., and White, D. S. 1987. PCB availability assessment of river dredging using caged clams and fish. *Environmental Toxicology and Chemistry*, 6: 259–274.
- Richardson, W. J., Davis, R. A., Evans, R., Ljungblad, D. K., and Norton, P. 1987. Summer distribution of bowhead whales, *Balaena mysticetus*, relative to oil industry activities in the Canadian Beaufort Sea, 1980–84. *Arctic*, 40: 93–104.
- Richardson, W. J., Fraker, M. A., Würsig, B., and Wells, R. S. 1985. Behaviour of bowhead whales *Balaena mysticetus* summering in the Beaufort Sea: reactions to industrial activities. *Biological Conservation*, 32: 195–230.
- Richardson, W. J., Würsig, B., and Greene, C. R., Jr. 1990. Reactions of bowhead whales, *Balaena mysticetus*, to drilling and dredging noise in the Canadian Beaufort Sea. *Marine Environmental Research*, 29: 135–160.
- Roberts, D. A. 2012. Causes and ecological effects of resuspended contaminated sediments (RCS) in marine environments. *Environment International*, 40: 230–243.
- Robinson, J. E., Newell, R. C., Seiderer, L. J., and Simpson, N. M. 2005. Impacts of aggregate dredging on sediment composition and associated benthic fauna at an offshore dredge site in the southern North Sea. *Marine Environmental Research*, 60: 51–68.
- Robinson, S. P., Theobald, P. D., Hayman, G., Wang, L. S., Lepper, P. A., Humphrey, V., and Mumford, S. 2011. Measurement of underwater noise arising from marine aggregate dredging operations. Marine Aggregate Levy Sustainability Fund MEPP report 09/P108.
- Rolland, R. M., Parks, S. E., Hunt, K. E., Castellote, M., Corkeron, P. J., Nowacek, D. P., Wasser, S. K., *et al.* 2012. Evidence that ship noise increases stress in right whales. *Proceedings of the Royal Society B: Biological Sciences*, 279: 2363–2368.
- Scholik, A. R., and Yan, H. Y. 2001. Effects of underwater noise on auditory sensitivity of a cyprinid fish. *Hearing Research*, 152: 17–24.
- Scholik, A. R., and Yan, H. Y. 2002. Effects of boat engine noise on the auditory sensitivity of the fathead minnow, *Pimephales promelas*. *Environmental Biology of Fishes*, 63: 203–209.
- Schustermann, R. J., Southall, B., Kastak, D., and Kastak, C. R. 2001. Pinniped vocal communication: form and function. *In* *17th International Congress on Acoustics*, p. 2. Rome, Italy.
- Scott, M. D., Wells, R. S., and Irvine, A. B. 1990. A long-term study of bottlenose dolphins on the west coast of Florida. *In* *The Bottlenose Dolphin*, pp. 235–244. Ed. by S. Leatherwood, and R. R. Reeves. Academic Press, San Diego.
- Shane, S. H. 1990. Behavior and ecology of the bottlenose dolphin at Sanibel Island, Florida. *In* *The Bottlenose Dolphin*, pp. 267–283. Ed. by S. Leatherwood, and R. R. Reeves. Academic Press, San Diego.
- Sherk, J. A., Jr. 1972. Current status of the knowledge of the biological effects of suspended and deposited sediments in Chesapeake Bay. *Chesapeake Science*, 13: S137–S144.
- Simpson, S. D., Meekan, M. G., Larsen, N. J., McCauley, R. D., and Jeffs, A. 2010. Behavioral plasticity in larval reef fish: orientation is influenced by recent acoustic experiences. *Behavioral Ecology*, 21: 1098–1105.
- Simpson, S. D., Radford, A. N., Tickle, E. J., Meekan, M. G., and Jeffs, A. G. 2011. Adaptive avoidance of reef noise. *PLoS ONE*, 6: e16625.
- Smith, M. E., Kane, A. S., and Popper, A. N. 2004a. Acoustical stress and hearing sensitivity in fishes: does the linear threshold shift hypothesis hold water? *Journal of Experimental Biology*, 207: 3591–3602.
- Smith, M. E., Kane, A. S., and Popper, A. N. 2004b. Noise-induced stress response and hearing loss in goldfish (*Carassius auratus*). *Journal of Experimental Biology*, 207: 427–435.
- Solé, M., Lenoir, M., Durfort, M., López-Bejar, M., Lombarte, A., and André, M. 2013. Ultrastructural damage of *Loligo vulgaris* and *Illex coindetii* statocysts after low frequency sound exposure. *PLoS ONE*, 8: e78825.
- Southall, B. L. 2005. Shipping noise and marine mammals: a forum for science, management, and technology. Final report of the NOAA International Symposium. p. 40. NOAA Fisheries Acoustics Program.
- Southall, B. L., Bowles, A. E., Ellison, W. T., Finneran, J. J., Gentry, R. L., Greene, C. R., Kastak, D., *et al.* 2007. Marine mammal noise exposure

- criteria, initial scientific recommendations. *Aquatic Mammals*, pp. 411–414.
- Spain, A. V., and Heinssohn, G. E. 1973. Cyclone associated feeding changes in the dugong (Mammalia: Sirenia). *Mammalia*, 37: 678–680.
- Stern, E. M., and Stickle, W. B. 1978. Effects of turbidity and suspended sediment in aquatic environments: literature review. US Army Corps of Engineers, Waterways Experiment Station Technical report DO-78-21. 117 pp.
- Suedel, B., Lutz, C., Clarke, J., and Clarke, D. 2012. The effects of suspended sediment on walleye (*Sander vitreus*) eggs. *Journal of Soils and Sediments*, 12: 995–1003.
- Taylor, S. E., Birch, G. F., and Links, F. 2004. Historical catchment changes and temporal impact on sediment of the receiving basin, Port Jackson, New South Wales. *Australian Journal of Earth Sciences*, 51: 233–246.
- Tervo, O. M., Christoffersen, M. F., Simon, M., Miller, L. A., Jensen, F. H., Parks, S. E., and Madsen, P. T. 2012. High source levels and small active space of high-pitched song in bowhead whales (*Balaena mysticetus*). *PLoS ONE*, 7: e52072.
- Thompson, T. J., Winn, H. E., and Perkins, P. J. 1979. Mysticete sounds. In *Behavior of Marine Animals: Vol. 3. Cetaceans*, pp. 403–431. Ed. by H. E. Winn, and B. L. Olla. Plenum.
- Thomsen, F., McCully, S. R., Weiss, L., Wood, D., Warr, K., Barry, J., and Law, R. 2011. Cetacean stock assessment in relation to exploration and production industry activity and other human pressures: review and data needs. *Aquatic Mammals*, 37: 1–93.
- Thomsen, F., McCully, S., Wood, D., Pace, F., and White, P. 2009. A generic investigation into noise profiles of marine dredging in relation to the acoustic sensitivity of the marine fauna in UK waters with particular emphasis on aggregate dredging: phase 1 scoping and review of key issues. Cefas MEPF Ref No. MEPF/08/P21. 59 pp.
- Thrush, S. F., and Dayton, P. K. 2002. Disturbance to marine benthic habitats by trawling and dredging: implications for marine biodiversity. *Annual Review of Ecology and Systematics*, 33: 449–473.
- Tillin, H. M., Houghton, A. J., Saunders, J. E., Drabble, R., and Hull, S. C. 2011. Direct and indirect impacts of marine aggregate dredging. Marine Aggregate Levy Sustainability Fund (MALSF). Science Monograph Series: No 1. 41 pp.
- Utne-Palm, A. C. 2002. Visual feeding of fish in a turbid environment: physical and behavioural aspects. *Marine and Freshwater Behaviour and Physiology*, 35: 111–128.
- van Dalen, J., and Essink, K. 2001. Benthic community response to sand dredging and shoreface nourishment in Dutch coastal waters. *Senckenbergiana Maritima*, 31: 329–332.
- van Dalen, J. A., Essink, K., Toxvig Madsen, H., Birklund, J., Romero, J., and Manzanera, M. 2000. Differential response of macrozoobenthos to marine sand extraction in the North Sea and the Western Mediterranean. *ICES Journal of Marine Science*, 57: 1439–1445.
- van der Veer, H. W. 1979. Effect van zandwinning in de Waddenzee op de waterkwaliteit. Eindrapport werkgroep II: Biologisch-Ecologisch Onderzoek met betrekking tot de winning van zand in de Waddenzee c.a. Rijkswaterstaat, Directie Friesland, Leeuwarden: 1–16.
- van der Veer, H. W., Bergman, M. J. N., and Beukema, J. J. 1985. Dredging activities in the Dutch Wadden Sea: effects on macrobenthic infauna. *Netherlands Journal of Sea Research*, 19: 183–190.
- Van Opzeeland, I., Van Parijs, S., Bornemann, H., Frickenhaus, S., Kindermann, L., Klinck, H., Plotz, J., et al. 2010. Acoustic ecology of Antarctic pinnipeds. *Marine Ecology Progress Series*, 414: 267–291.
- Van Waerebeek, K., Baker, A. N., Félix, F., Gedamke, J., Iñiguez, M., Sanino, G. P., Secchi, E., et al. 2007. Vessel collisions with small cetaceans worldwide and with large whales in the Southern Hemisphere, an initial assessment. *Latin American Journal of Aquatic Mammals*, 6: 43–69.
- Vanderlaan, A. S. M., and Taggart, C. T. 2007. Vessel collisions with whales: the probability of lethal injury based on vessel speed. *Marine Mammal Science*, 23: 144–156.
- Velegrakis, A. F., Ballay, A., Poulos, S., Radzevicius, R., Bellec, V., and Manso, F. 2010. European marine aggregates resources: origins, usage, prospecting and dredging techniques. *Journal of Coastal Research*, (Special Issue) No. 51: 1–14.
- Voellmy, I. K., Purser, J., Flynn, D., Kennedy, P., Simpson, S. D., and Radford, A. N. 2014. Acoustic noise reduces foraging success in two sympatric fish species via different mechanisms. *Animal Behaviour*, 89: 191–198.
- Vos, J. G., Bossart, G., Fournier, M., and O'Shea, T. 2003. *Toxicology of Marine Mammals. New Perspectives: Toxicology and the Environment*. CRC Press, Taylor & Francis Group, London.
- Walker, T. A., and O'Donnell, G. 1981. Observations on nitrate, phosphate and silicate in Cleveland Bay, Northern Queensland. *Australian Journal of Marine and Freshwater Research*, 32: 877–887.
- Weiffen, M., Moller, B., Mauck, B., and Dehnhardt, G. 2006. Effect of water turbidity on the visual acuity of harbour seals (*Phoca vitulina*). *Vision Research*, 46: 1777–1783.
- Weilgart, L. S. 2007. The impacts of anthropogenic ocean noise on cetaceans and implications for management. *Canadian Journal of Zoology*, 85: 1091–1116.
- Weller, D., Burdin, A., Wursig, B., Taylor, B., and Brownell, R., Jr. 2002. The western gray whale: a review of past exploitation, current status and potential threats. *Journal of Cetacean Research and Management*, 4: 7–12.
- Wenger, A. S., and McCormick, M. I. 2013. Determining trigger values of suspended sediment for behavioral changes in a coral reef fish. *Marine Pollution Bulletin*, 70: 73–80.
- Wenger, A. S., McCormick, M. I., McLeod, I. M., and Jones, G. P. 2013. Suspended sediment alters predator–prey interactions between two coral reef fishes. *Coral Reefs*, 32: 369–374.
- Wilber, D. H., Brostoff, W., Clarke, D. G., and Ray, G. L. 2005. Sedimentation: potential biological effects of dredging operations in estuarine and marine environments. US Army Engineer Research and Development Center DOER-E20. 15 pp.
- Wilber, D. H., and Clarke, D. G. 2001. Biological effects of suspended sediments: a review of suspended sediment impacts on fish and shellfish with relation to dredging activities in estuaries. *North American Journal of Fisheries Management*, 21: 855–875.
- WODA. 2013. Technical Guidance on: Underwater Sound in Relation to Dredging World Organisation of Dredging Associations.
- Wong, C. K., Pak, I. A. P., and Jiang Liu, X. 2013. Gill damage to juvenile orange-spotted grouper *Epinephelus coioides* (Hamilton, 1822) following exposure to suspended sediments. *Aquaculture Research*, 44: 1685–1695.
- Wright, A., Soto, N., Baldwin, A., Bateson, M., Beale, C. M., Clark, C., Deak, T., et al. 2007. Do marine mammals experience stress related to anthropogenic noise? *International Journal of Comparative Psychology*, 20: 274–316.
- Zieman, J. C., and Zieman, R. T. 1989. The ecology of the seagrass meadows of the west coast of Florida: a community profile. US Fish and Wildlife Research Service. US Fish and Wildlife Service Biological Report 85 (7.25) for the US Department of the Interior. 155 pp.

Handling editor: Kees Camphuysen